

Capacity: 2½", 3", 3½", & 4"

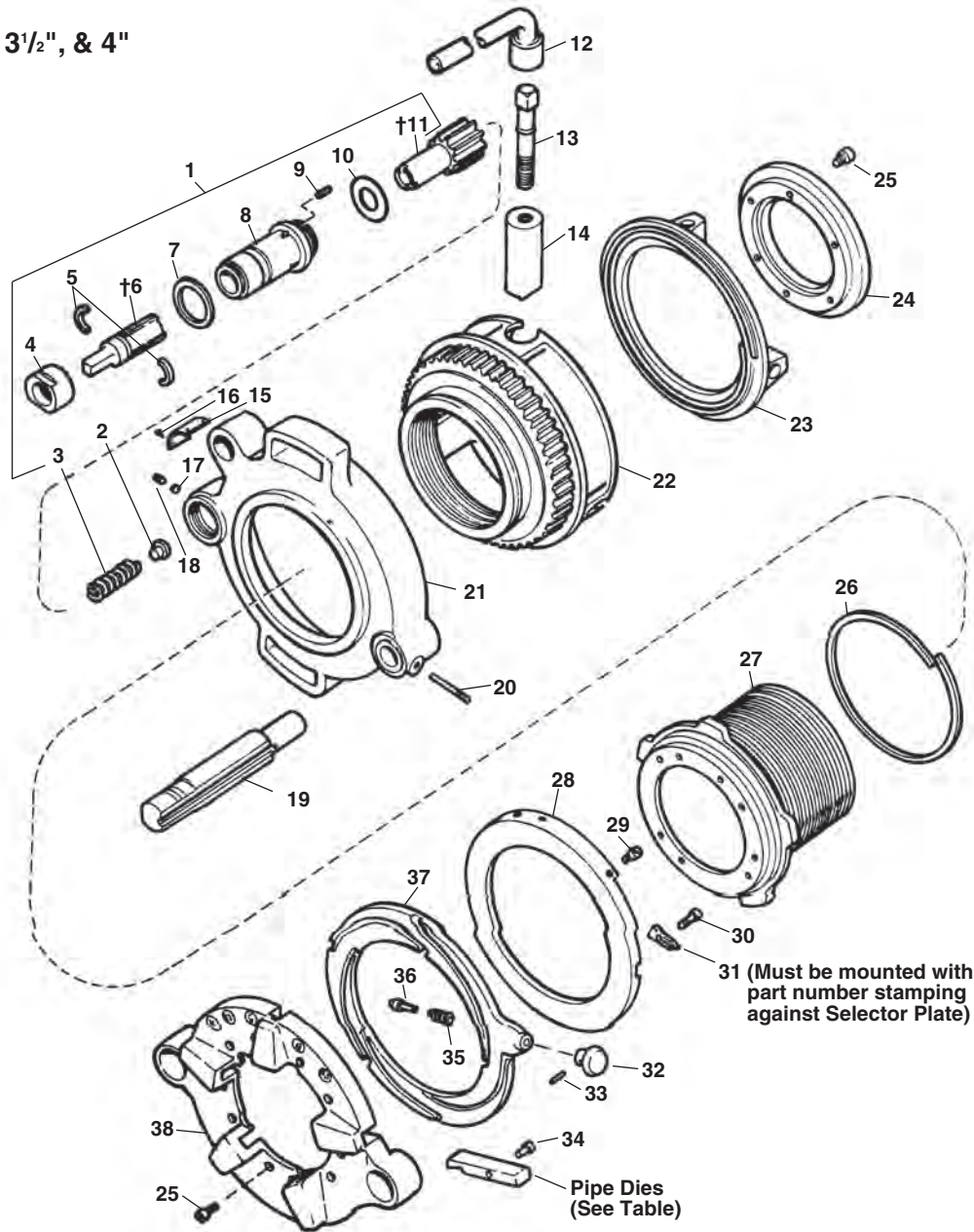

NOTE: Order parts by Catalog Number only. DO NOT order by Reference Number.

Ref. No.	Catalog No.	Description	Ref. No.	Catalog No.	Description	Ref. No.	Catalog No.	Description
1	39360	Pinion Shaft Assembly	14	39345	Workholder Jaw (3)	27	39320	NPT Threaded Barrel
2	39810	Wear Plug	15	39835	Name Plate		68090	BSPT Threaded Barrel
3	39815	Spring	16	46870	Drive Screw (4)	28	39185	NPT Selector Plate
4	39605	Pinion Shaft Retaining Collar	†17	32755	Nylon Plug		39190	BSPT Selector Plate
5	39695	Split Ring	18	58720	Set Screw		39110	Selector Plate f/ Cast Iron
†6	39465	Drive Shaft	19	39330	NPT Guide Post	29	39790	Stop Screw
7	39615	Pressure Ring		68020	BSPT Guide Post	30	39830	Guide Block Screw
8	39825	Pinion Sleeve	20	39650	Guide Post Screw	31	39655	Guide Block
9	39620	Pressure Pin (3)	21	39200	Gear Case	32	39645	Knob (2)
10	39625	Pinion Shaft Ring	22	39195	NPT Workholder	33	44925	Pin (2)
†11	39470	Pinion Shaft with Gear		68040	BSPT Workholder	34	39750	Die Pins & Clips
12	39585	Wrench	23	39100	Workholder Scroll	35	39690	Spring (2)
	29056	Wrench (Europe Hex-Key)	24	39455	Retaining Ring	36	39640	Locating Pin (2)
13	39795	Clamp Screw with Clip	25	32275	Screw (16)	37	39180	Cam Plate
	29046	Clamp Screw with Clip (Europe)	26	39730	Gear Case Spring Ring	38	39175	Head

Service Notes: (Ref. No. 6) (Ref. No. 11) Early Models incorporating 39600/E-1936 Pinion Shaft and 3590/E-1935-1 Drive with 39630/E-1945-1 Centering Pin can be updated by using new style Pinion Shaft or new style Drive Shaft and discarding Centering Pin.
 (Ref. No. 17) Nylon Plug should be replaced anytime Pinion Shaft Assembly (Ref. No. 1) is removed from Gear Case.